

Tone King

“Imperial MK II”

User's Manual



Tone King Amplifiers
www.toneking.com
mail@toneking.com

Note from the Builder

Thank you for choosing the Imperial MK II guitar amplifier. The Imperial was the very first production model built by Tone King. It was introduced in 1993, and has been a favorite of guitarists for over 20 years now. The MK II update incorporates all that I've learned as an amp designer over these past 20 years, without changing the essential character of the amp. If anything, the MK II digs deeper for an even more authentically vintage sound and feel.



I designed the Imperial back in 1990-1993. At the time, I was inspired by listening to vintage amps such as the Fender Deluxe Reverb and the Fender Tweed Deluxe. It was clear that the authentic vintage amps had a certain mojo that was missing in modern amps. They had a certain feel that made you want to play them – a compliant, broken-in feel. They also had a certain transparency to their tone, a harmonic complexity, and an expressive quality that I couldn't find in new amps at the time. My goal was to build a new amp that could capture that vintage magic.

Being an Electrical Engineer, I was able to absorb a lot of the electronic necessities of such as design fairly readily, but I hit a stopping point when it came to the cabinet design. After prototyping electronic designs using a fine sounding vintage speaker cabinet, I became quite aware of the important role the cabinet can play once I built my first speaker cabinet, to disappointing results. After years of building test cabinets, experimenting with wood types, construction methods, and many other factors, I began to develop a sense for how to control the voicing of a cabinet to achieve the sound and feel I was after. The Imperial was the first of my designs to benefit from these efforts in cabinet design, and I like to think that this is why it is such a special amp that has been so successful for all these years.

Still, being primarily an experimenter, I never stopped trying to learn new ways to improve my designs. This new MK II design incorporates development work I've done over the past 20 years, and represents the best of what I can do at this time.



To be specific, the MK II is built using a layout scheme I'm calling "handwired board", which I believe to be an ideal construction method to extract the best tone from any circuit design. It has great advantages in terms of component placement, wiring length, and wire routing, and has a real, tangible effect on the sound and feel of an amp.

In addition, the MK II includes the new Ironman/II attenuator, which I feel is a great advance in that it provides fletcher-munson volume compensation to correct for the way the ear perceives sound at low volume, as well a circuitry that compensates for the way the speaker operates at low volume, to preserve the experience of playing a cranked amp at low volume better than had been done before.

I thank you for your purchase of this special version of the Imperial, and I hope you enjoy playing it as much as I do.

Tone King Amplifiers,

Safety Instructions

Please keep this instruction manual for future reference and for the duration of owning this Tone King Amplifier. Please carefully read and understand the instructions inside this user's manual before attempting to operate your new amp. This instruction manual includes essential safety information regarding the use and maintenance of the amplifier. Take special care to heed all warning symbols and signs inside this manual and those printed on the amplifier itself.



WARNING!

TO PREVENT FIRE OR SHOCK HAZARD, DO NOT EXPOSE THE AMPLIFIER TO WATER OR MOISTURE. DO NOT OPERATE NEAR ANY WATER SOURCE



WHAT'S THE MEANING OF THIS?

The lightning flash with an arrow triangular symbol is intended to alert the user to the presence of non-insulated "dangerous voltage" within the products enclosure, and may be of sufficient magnitude to constitute a risk of electric shock



WHAT'S THE MEANING OF THIS?

The exclamation point triangular symbol is intended to alert the user to the presence of important operating and maintenance (servicing) instructions in the user manual accompanying this amplifier!

1. Read Instructions – All the safety and operating instructions should be read before this product is operated.
2. Retain Instructions – The safety and operating instructions should be retained for future reference.
3. Heed Warnings – All warnings on the amplifier and in the operating instructions should be adhered to.
4. Follow Instructions – All operating and use instructions should be followed.
5. Water and Moisture – The amplifier should not be used near water – for example, a bathtub, washbowl, kitchen sink, laundry tub, wet basement, or near a swimming pool, and the like.
6. Carts and Stands – The amplifier should be used only with a cart or stand that is recommended by the manufacturer.
An amplifier and cart combination should be moved with care. Quick stops, excessive force, and uneven surfaces may cause the amplifier and cart combination to overturn.
7. Wall or Ceiling Mounting
– The product should never be mounted to a wall or ceiling.

8. Heat – Amplifier should be situated away from heat sources such as radiators, heat registers, stoves, or other amplifier (including amplifiers) that produce heat.
9. Power Sources – This product should be operated only from the type of power source indicated on the rating label.
If you are not sure of the type of power supply to your home, consult your product dealer or local power company.
10. Grounding or Polarization
– This product may be equipped with a polarized alternation-current line plug (a plug having one blade wider than the other). This plug will fit into the power outlet only one way. This is a safety feature. If you are unable to insert the plug fully into the outlet, try reversing the plug. If the plug should still fail to fit, contact your electrician to replace your obsolete outlet. Do not defeat the safety purpose of the polarized plug.
11. Power-Cord Protection
– Power-supply cords should be routed so that they are not likely to be walked on or pinched by items placed upon or against them, paying particular attention to the cord in correspondence of plugs, convenience receptacles, and the point where they exit from the amplifier.
12. Cleaning – The amplifier should be cleaned only as recommended by the manufacturer. Clean by wiping with a cloth slightly damp with water. Avoid getting water inside the amplifier.
14. Non-use Periods – The power cord of the amplifier should be unplugged from the outlet when left unused for a long period of time.
15. Object and Liquid Entry
– Care should be taken so that objects do not fall and liquids are not spilled into the enclosure through openings.
16. Damage Requiring Service
– The amplifier should be serviced by qualified service personnel when:
A. The power-supply cord or the plug has been damaged; or
B. Objects have fallen, or liquid has been spilled into the amplifier; or
C. The amplifier has been exposed to rain; or
D. The amplifier does not appear to operate normally or exhibits a marked change in performance; or
E. The amplifier has been dropped, or the enclosure damaged.
F. The amplifier needs tube replacement or biasing
17. Servicing – The user should not attempt any service to the amplifier beyond that described in the operating instructions.
All other servicing should be referred to qualified service personnel.
18. Ventilation – Slots and openings in the cabinet are provided for ventilation and to ensure reliable operation of the product and to protect it from overheating, and these openings must not be blocked or covered. The openings should never be blocked by placing the product on a bed, sofa, rug, or other similar surface. This product should not be placed in a built-in installation such as a bookcase or rack.
19. Attachments – do not use attachments not recommended by the product manufacturer as they may cause hazards.
20. Accessories – Do not place this product on an unstable cart, stand, tripod, bracket, or table. The product may fall, causing serious injury to a child or adult, and serious

damage to the product. Use only with a cart, stand, tripod, bracket, or table recommended by the manufacturer, or sold with the product.

21. Lightning – For added protection for this product before a lightning storm, or when it is left unattended and unused for long periods of time, unplug it from the wall outlet.

This will prevent damage to the product due to lightning and powerline surges.

22. Replacement Parts – When replacement parts are required, be sure the service technician has used replacement parts specified by the manufacturer or have the same characteristics as the original part. Unauthorized substitutions may result in fire, electric shock, or other hazards.

23. Safety Check – Upon completion of any service or repairs to this product, ask the service technician to perform safety checks to determine that the product is in proper operating condition.

24. FUSES – Always use the correct rating and type of fuse as indicated on the rear panel. Note the proper rating fuse is determined by the AC line voltage in the country this unit is being operated.

25. AC SELECT SWITCH: This switch must be set to match the AC line voltage in the country this unit is being operated.

To change the setting, loosen (do not remove) the two screws above and below the slide switch. Temporarily move the protective cover strip and slide the actuator to match the voltage in your country. Place the protective cover strip back over the switch and tighten the two screws.

Contents

1. Front Panel Controls	4
Two Preamp Channels – Lead and Rhythm	4
Rhythm Channel	4
Lead Channel	5
Reverb	6
Tremolo (Rate & Depth)	6
2. Back Panel Controls	7
AC Power	7
Fuse	7
Power Switch, Standby Switch	7
Footswitch	7
Speaker Jack	8
Attenuation Controls	8
3. Ironman/II Attenuator	9
Purpose of the Attenuator	9
Attenuator Controls	10
How to Use The Attenuator	10
HF Comp Switch	11
Rhythm Channel Bypass Switch	11
4. Getting a Great Sound at Home	12
The Effect of Your Acoustical Environment	12
Floor Reflections	12
Where to Place the Amp	12
Carpeting	12
Backwards Amp Trick	13
The Attenuator Can Help	13
5. Tube Installation and Replacement	14
Choice of Tube Types and Brands	14
Alternate Tube Choices	15
Installing Tubes	15
Replacing Output Tubes	15
Tube Quality	16
6. Warranty	17
7. CE Declaration	18

1. Front Panel Controls

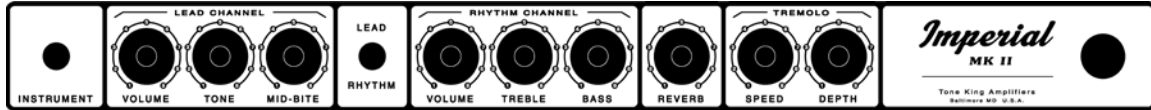

Two Preamp Channels – Lead and Rhythm

The Imperial has two separate preamplifier channels, each with its own unique voicing. You can switch between the channels with either the “Lead/Rhythm” switch (on the front panel) or with the “Channel” switch on the footswitch. When using the footswitch, you should set the front panel switch to the “Rhythm” position. You’ll notice that the LED on the footswitch indicates the channel selected. When the LED is lit, the Lead channel is selected. When the LED is not lit, the Rhythm channel is selected.

Rhythm Channel

The Rhythm channel includes controls for Volume, Treble, and Bass. This channel is designed to deliver a “vintage 1960’s clean tone”. In previous versions of the Imperial, it had been suggested that this channel be used only for clean tones, since its overdriven sound could become a bit harsh. However, layout improvements made in this new MK II design have had a big effect on the overdriven tone of the Rhythm channel. It can now deliver a fantastic range of usable overdriven tones in addition to its sparkling clean tone.

The Bass and Treble controls act much like they would on a genuine vintage amp of this type. Here are two sample settings that demonstrate the sound that the Rhythm channel was designed to deliver:

Clean Rhythm Tone

Volume	Treble	Bass	Reverb
3	4	6	5

This is the clean sound the Imperial was designed for. Sweet, punchy, and balanced. Plug in a strat with the (bridge+middle) position, and you’ll get a nice ‘Sultans of Swing’ tone. Try the middle pickup position of a tele to get a nice rich sound with just the right amount of bite on top. Bridge pickup settings on any single coil guitar should give you a nice balance – great clarity and just the right amount of brightness.

Cranked Rhythm Channel Overdrive

Volume	Treble	Bass	Reverb
8	5	6	4

Here’s a great setting that sounds like an old twin reverb run flat out on 10. It’s perfect for plugging in your telecaster and pulling out those Roy Buchanan licks. A strat can be great as well, using the bridge pickup. You may want to use the attenuator with this setting – it will be loud otherwise.

Lead Channel

The Lead channel starts out with a Tweed style preamp, which drives a proprietary tone-shaping circuit built around the Mid-Bite control, a unique Tone King feature. This proprietary circuit transforms the basic tweed tone to more of a crunchy rock tone as you turn up the mid-bite control. This is accomplished by simultaneously tightening up the bass, rolling off the very high frequencies, increasing the gain, and developing a pronounced upper midrange peak. The Mid-Bite control is the key to dialing in your own particular sound on the lead channel, so you may want to experiment and observe its effect as you rotate it from 1 to 9.

Here are a few sample settings which demonstrate the tones that the Lead channel is designed to deliver:

Old Style Fat Clean

Volume	Tone	Mid-Bite	Reverb
2	3	1	1

This is a nice setting that has many uses. It's a fatter clean sound than you get from the Rhythm channel, with a slight boxiness and a smooth top end. Plug in a telecaster, and it's perfect for honky tonk or old time country music. Plug in a hollowbody jazz box, and you'll get pretty close to Wes Montgomery or Grant Green tones.

Fat Tweed Overdrive

Volume	Tone	Mid-Bite	Reverb
9	4	1	3

This setting is a nice chunky overdriven sound inspired by the sound of a tweed deluxe on 10. It's great for blues playing, and really shines with single notes and double stops.

Rock & Roll Tweed Overdrive

Volume	Tone	Mid-Bite	Reverb
6	5	8	2

This setting is more rock & roll, but still retains a lot of the 'tweed deluxe' character. It gives you a tighter bottom end and creamier mids than the previous setting, so it's great for playing rock chord rhythms and singing single-note lines. When using this setting, I'm tempted to pull out some Billy Gibbons licks, or possibly something like 'Cat Scratch Fever', but I'm sure you'll find many great uses for it.

Reverb

The Imperial includes a built in 2-spring, tube-driven reverb circuit. Reverb is applied to both the Rhythm and Lead channels. In order to compensate for the higher gain of the Lead channel, the reverb drive is reduced slightly on the Lead channel. This reduction helps to match the reverb level when switching between preamp channels, when the Lead channel is being driven hard and the Rhythm channel is set for a clean tone.

The Reverb level is controlled by the front panel Reverb control, which adjusts the amount of the reverb signal which is mixed into the signal path.

Tremolo (Rate & Depth)

The Imperial's tremolo circuit is a modified form of the old-fashioned "bias modulation" tremolo circuit. This circuit achieves the tremolo effect by varying the bias of the output tubes. This type of tremolo was used in all Tone King amps going back to 1993. However, the Imperial MK II uses a modified form of this circuit which virtually eliminates the "thumping" and other sonic effects that are typical for this type of effect. This is the same circuit which was used on the 20th Anniversary Imperial.

This type of tremolo circuit gives you a nicely rounded effect, but it is quite subtle when compared to an opto-coupler tremolo (as would be found in, for example, a Fender Twin Reverb).

The "Depth" control varies the intensity of the modulation effect, and the "Rate" knob controls the speed of the effect.

If the footswitch is not being used, then the tremolo circuit is active all the time, so you will need to turn the "Depth" knob all the way down if you do not wish to use tremolo.

When the footswitch is plugged in, you can turn the tremolo on and off with the footswitch. An LED shows the status of the effect (LED on = tremolo on)

2. Back Panel Controls

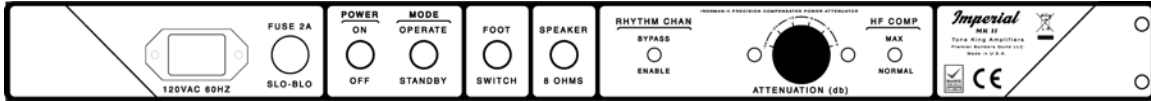

AC Power

Always use a grounded AC cord, and make sure that a proper ground connection is supplied to the amp. Never attempt to lift or defeat the ground connection to the amp.

Fuse

A standard 2A slo-blo fuse (style 3AG) should be used.

Power Switch, Standby Switch

When powering up the amp, you should start with both the Power and Standby switches in the "off" position.

First, turn on the Power switch. This will apply power only to the tube filaments and the low-voltage circuitry.

After turning on the Power switch, allow the tubes to warm up for about 1 minute, then turn on the Standby switch.

The power-down sequence is not as important as the power-up sequence. When turning the amp off, you may turn Power off before Standby, or turn Standby off before Power, or turn them both off at the same time.

Footswitch

Connect the footswitch to the amp with the supplied cable, or with any standard ¼" TRS (Stereo) -to- ¼" TRS (Stereo) cable.

The footswitch allows you to control both the preamp channel selection and the tremolo on/off. LEDs indicate the current switching status, as follows:

Channel switch: LED on = Lead channel

Tremolo switch: LED on = Tremolo on

When using the footswitch, make sure to set the front panel Channel switch to the Rhythm position.

Speaker Jack

The Imperial has a single speaker jack with an impedance of 8 Ohms. If you wish to use an extension cabinet, it's best to use an 8-ohm cabinet. You can connect it with a standard ¼" mono speaker cable by pulling out the plug from the internal speaker, and plugging the cable into the speaker jack.

If desired or necessary, you may safely mismatch the impedance by as much as doubling or halving the selected impedance. Mismatching beyond this is not recommended. For example, you may safely use a total speaker load as low as 4 ohms or as high as 16 ohms.

Ironman/II Compensated Power Attenuator

The Imperial MK II contains the new Ironman-II precision compensated power attenuator. The Ironman-II's new architecture goes a step beyond the original Ironman design. It includes circuitry which helps compensate for the way your ear perceives sound at very low volume, and also for the way the speaker performs at very low power. This compensation circuitry helps preserve the full, rich sound with plenty of presence at even bedroom volume.

The operation of the Ironman/II will be described in detail in the following section.

3. Ironman/II Attenuator

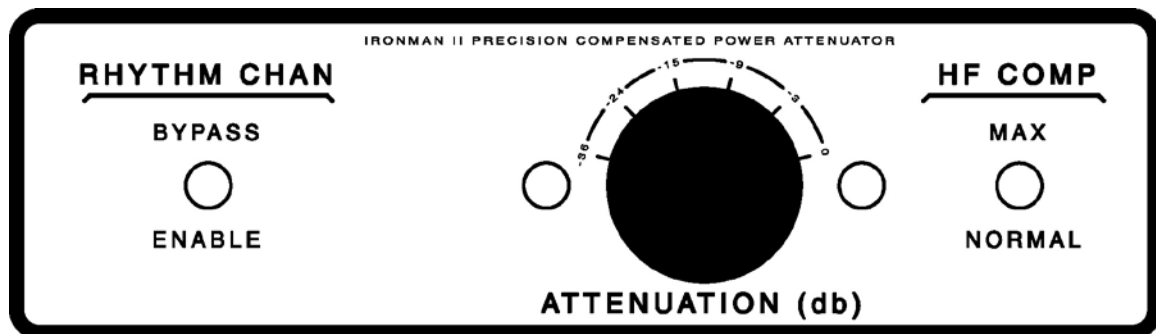

Purpose of the Attenuator

The Imperial is designed so that, when driven into overdrive and distortion, most of the distortion is generated in the output tubes (and the phase inverter). Output stage distortion has a different sound and feel than distortion generated in the preamplifier, and this is big part of why the Imperial sounds the way it does. The problem with this sort of design is that the only way to generate any overdrive or distortion is to push the output stage to the maximum output power, which means it will be very loud. This level of volume is impractical for many circumstances, so it is necessary to find a way to lower the volume level while still maintaining the great sound of overdriven power tubes.

The best solution to controlling volume level while still allowing the output tubes to generate maximum output power is to use an attenuator. An attenuator is a circuit which allows you to divide the power generated by the amplifier between the speaker and a specially designed load circuit. In doing so, you can adjust the amount of power sent to the speaker, with the rest of the remaining power being absorbed in the load circuit, as shown in the diagram below:

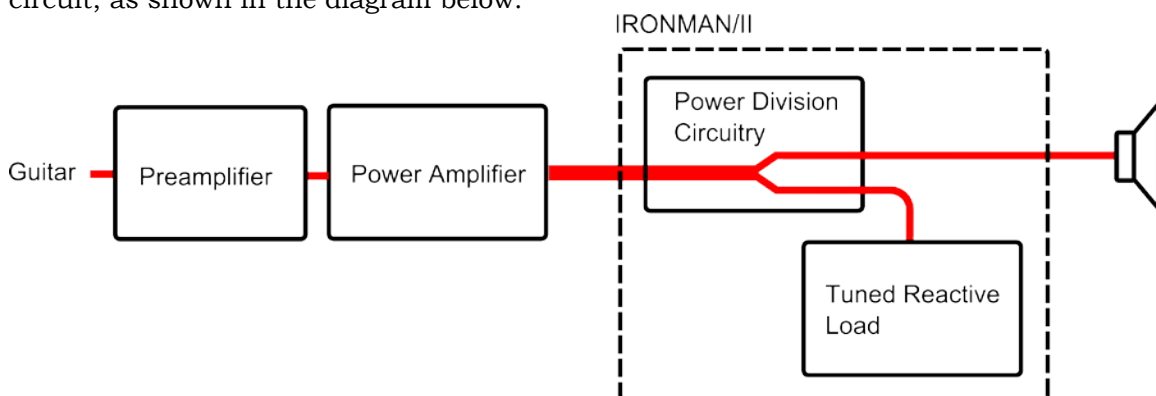

Attenuator Controls

As you can see from the illustration on the previous page, the attenuator controls consist of one rotary knob to select the attenuation level, and two switches to control other functions which will be described below.

On the Attenuation dial, 0db is the loudest setting. In this setting, the attenuator is fully bypassed, and the speaker is connected directly to the output of the amplifier. The -36db setting is the quietest setting. In this setting, most of the power generated by the output tubes is absorbed by the attenuator, and only a few dozen milliwatts of power are sent to the speaker.

How to Use the Attenuator

First, let's start with the basics of how to use the attenuator. For practical purposes, the Attenuation knob can be thought of as providing the same function as a "master volume" control. This means that you will use the "Volume" controls to adjust the gain of the preamp and the amount of overdrive/distortion you wish to dial in, and you will use the "Attenuation" dial to set the volume level that you wish to produce.

You may wish to experiment to confirm this behavior. For example, try selecting the lead channel, and setting the amp up like this:

Volume	Tone	Mid-Bite	Reverb	Attenuation	HF Comp
6	5	8	2	-24db	Max

Now, while playing through the amp, try turning the Volume control up and down a bit. You will see how slight changes in the Volume control will make the tone more or less distorted, but won't have much effect on the volume level in the room. The reason for this is that the output stage of the amplifier is already generating maximum output power even if the amp is only just on the edge of breakup. As you turn up the Volume control past this point, the output stage cannot produce any more power – it just becomes more overdriven.

After trying that experiment, set the volume control back to 6, where you started, and try adjusting the attenuation knob on the back of the amp. You will see that the volume level in the room changes, but the amount of overdrive and distortion does not. This is the purpose of the attenuator.

HF Comp Switch

As was previously mentioned, the Ironman/II contains special compensation circuitry to adjust the EQ curve and the amount of compression/presence progressively as the Attenuation knob is turned from 0 to its maximum setting of -36db. The HF Comp switch allows you to select between two different levels of compensation, Max and Normal. The Max setting will give you a bit more presence and a brighter sound. The Normal setting will give you a little more compression, and a smoother top-end.

The purpose of this switch is to help you match the sound of the amp to the acoustic properties of your room. The characteristics of the room have a much bigger influence on the sound when you are attenuating down to a low volume than they do at high volume. By having two levels of compensation, you have the ability to tailor the amount of presence and compression to complement the characteristics of your room.

For example, if you are playing in a very bright sounding room, then you might choose the Normal setting. Alternatively, if you are playing in a larger, more reflective room that tends to muddy the sound of an amp, you might prefer the Max setting.

The proper setting is a matter of personal preference, so you may want to try both and pick the one that appeals most to you.

Rhythm Channel Bypass Switch

This switch solves a particular problem: If you want to switch back and forth between an overdriven sound on the lead channel and a squeaky clean sound on the Rhythm channel, you may find it difficult to get enough clean volume on the Rhythm channel to match the overdriven volume on the Lead channel.

This switch solves the problem. Here's how it works:

Bypass: When set to 'Bypass', the attenuator is bypassed whenever the rhythm channel is selected. This means that the full power developed by the output tubes will be delivered to the speaker when the Rhythm channel is selected, regardless of the Attenuation knob setting. However, when you switch to the Lead channel, the attenuator will become active again, and will reduce the volume level according to the setting of the Attenuation knob.

In this mode, as you switch between Lead and Rhythm channels (using either the front panel Channel switch or the footswitch), the attenuator will automatically be turned off (bypassed) and on (enabled), depending on the channel you have selected.

Enable: In this mode, the attenuator will be on (enabled) no matter what channel is selected.

4. Getting a Great Sound at Home

The Effect of Your Acoustical Environment

When playing in a large room or on a big stage, getting a great sound from your amp is easy. Generally, in this type of setting, you would simply crank the amp up to full power, and it will sound great.

Playing at home, or in any small room, is a different story. In a case like this, the acoustic properties of the room can have more of an influence than the amplifier can, and will often conspire to cause real problems with the sound you hear from your amplifier.

There are many types of problems that can happen in a small room. Here are a few suggestions for how to deal with them:

Floor Reflections

If you have the amp sitting on a hardwood, tile, or concrete floor in a small room, it may sound harsh in the upper midrange, because of reflections off the floor in front of the amp. To help solve this problem, you might try placing a small piece of carpet (or a doormat, for example), directly in front of the amp.

Where to Place the Amp

To begin, it should be noted that the Imperial is always at its best when placed directly on the floor (with one exception, which will be noted later). If it is positioned off the floor, on a stand or some other device, the tonal balance will not be optimal. It will sound thinner and brighter than it should.

Next, you will find that the sound you hear is greatly influenced by where you place the amp in the room, and by the orientation of the amp with respect to the listening position (i.e. if the amp is pointing at you or away from you).

I strongly suggest experimenting by moving the amp around to different places in the room, playing through it at each location, to find the place that sounds the best.

You will also notice that the sound of the amp changes dramatically depending on whether you are listening to it on-axis (pointed directly at you) or off-axis (pointed away from you). I generally suggest a slightly off-axis listening position. You may want to experiment to find the best orientation for your listening room.

Carpeting

Carpeting can cause problems as well, and it's not quite as simple as rolling off the high frequencies and making the amp sound dark. Often, the problem is that it causes a dip in a certain region in the midrange, leaving a hole in the lower midrange that makes the amp sound harsh and brittle in the top end. This generally can't be helped by moving the amp to a different location in the room. The only solution I've found is to raise the amp up a few inches off the floor. You may lose some bottom end in doing this, but the positive effect in smoothing the midrange response will more than make up for it.

Backwards Amp Trick

Some small rooms have such problematic acoustical properties that you must take more drastic measures to get the best amp sound. Here's a trick you may have seen used on stage. If you are a fan of Roy Buchanan, as I am, you may have seen videos of live performances where he places the amp backwards, so that the back of the amp faces the audience. His reasons for doing this in a live performance are somewhat different than our concerns here, but still I'd suggest trying this if you are having problems with your amp's sound in a small room. If you are having trouble with the amp sounding peaky in the upper midrange, or generally too bright in your room, try turning it around so that the back of the amp faces you. This can make big difference in a bright sounding room.

The Attenuator Can Help

So far, we've discussed using the attenuator to control the volume in the case where we're driving the amp into overdrive and distortion. However, it can also help greatly with clean tones in a problematic room as well.

Usually, in a good sounding room, you would set the attenuation knob to 0db or bypass the attenuator when dialing in a clean tone. This always gives you the most headroom, and the most apparent clarity and dynamics.

However, if you are finding that the amp sounds harsh in your room, and that it's hard to control the volume because you are using a setting between 1 and 2 on the Volume knob, then the attenuator can help. Try setting the attenuator down a few steps (e.g. try it at -15db), with the HF Comp switch set to Max, and turn the Volume control up a bit to compensate. You should find that this smoothes out the upper mids and fattens up the tone without losing presence.

5. Tube Installation and Replacement

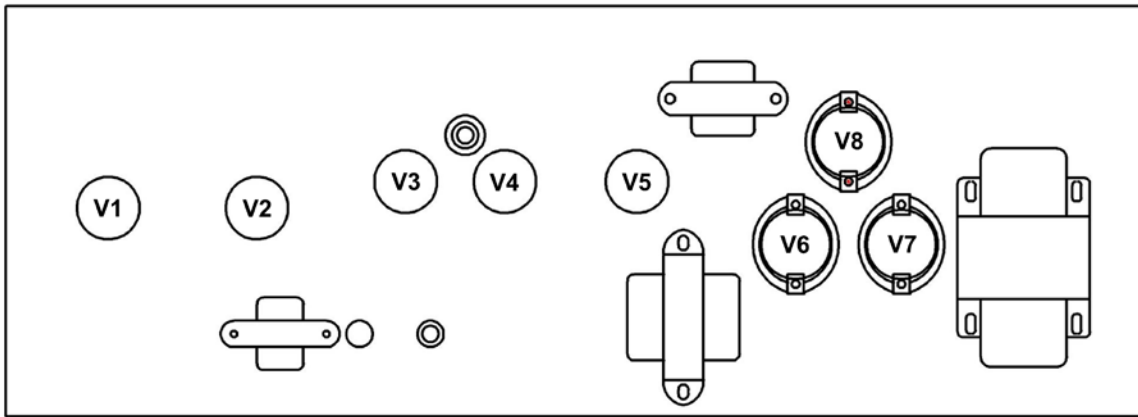

Choice of Tube Types and Brands

I currently recommend the following tube types:

No.	Type and Brand	Function
V1	TAD 12AX7A-C/Tung Sol 12AX7A	Stage 1 (Rhythm+Lead), Stage 2 (Lead)
V2	TAD 12AX7A-C/Tung Sol 12AX7A	Stage 2 (Rhythm), Stage 3 (Lead)
V3	EH 12AT7	Reverb Driver
V4	TAD 12AX7A-C/Tung Sol 12AX7A	Reverb receiver
V5	TAD 12AX7A-C/Tung Sol 12AX7A	Phase Inverter
V6-V7	TAD 6V6	Output Tubes
V8	TAD/Sovtek 5AR4	Rectifier

The tube brands shown above are my own preferences. You may want to use other brands, to tailor the sound to your own tastes. Here are a few notes on the various brands available today:

6V6 WARNING !

The following brands are NOT recommended, as we've experienced a high rate of red-plating and short circuit faults with these:

- Tung Sol 6V6GT
- EH 6V6GT manufactured after December 2014

We had been recommending EH brand 6V6s for years. These were great tubes, but some time around December 2014, the manufacturer changed the design, and they now appear to share the same construction as the Tung Sol 6V6. After the design change, we noticed the same reliability problems as the Tung Sol 6V6, so we no longer recommend using the EH 6V6 of current manufacture.

6V6 Tube Choices:

I prefer the TAD 6V6 for its warmth, smooth compression, and balanced top end.

The JJ brand 6V6 is another acceptable choice. The JJ 6V6 has a bigger, fatter sound than the TAD, but is a bit less lively sounding, and has a more muted top end. It sounds a bit more like a 6L6 than a 6V6.

12AX7 Tubes:

Both the TAD 12AX7A-C, and the Tung Sol 12AX7A are a great match for the Imperial MK II. Both have a nice balance of detail and warmth, with the Tung Sol having perhaps a bit more transparency in the top end, and the TAD having a bit less glassiness but still a nice presence in the upper mids.

EH 12AX7s are very similar to Tung Sol 12AX7s – both are very quiet with very low microphonics and are a bit on the bright side, with an extended top end. Tung Sols seem a bit warmer than EHs.

The Svetlana 12AX7, a short-plate tube, has nearly the clarity of the 12AX7EH, and slightly more bottom end, but is a bit congested in the midrange. Years ago, I had selected this brand as the brand of choice for the Meteor/II amp, but later changed to a combination of the 12AX7EH and the 12AX7LPS.

Sovtek 12AX7LPS – this long-plate 12AX7 has a big, warm sound that comes close to a good NOS long-plate 12AX7. However, this tube can tend to be microphonic.

Alternate Tube Choices You May Want to Try

Reducing Gain: If you find the preamp too gainy, and you find that you're setting the volume controls down quite low to get sufficient clean headroom, you may want to try swapping in a 12AU7 in the V2 position. You can reduce the gain further by swapping a 12AU7 into the V1 position as well.

Adding Sag / More Compression: If you'd like a little less output power, and a little looser feel, you might try changing the rectifier tube to a 5Y3. My preference is an old NOS RCA 5Y3 – these sound better than current production 5Y3s.

Installing Tubes

When installing tubes, you may find it helpful to lay the amp on its face (speaker pointing toward the ground), on a table, and shine a light directly into the back of the amp, to aid in locating the position of each tube. Tubes must be installed in the correct orientation. The smaller, all-glass tubes have a blank space in the ring of pins which must line up with the blank space in the ring of tube pins in the tube socket, located on the chassis. The larger, bakelite-base tubes have a small cylinder with an indexing key in the center of the ring of tube pins, and this indexing key must match up with the corresponding slot in the socket on the chassis.

Replacing Output Tubes

The output stage of the Imperial is fully cathode biased, and no bias adjustment is necessary when changing output tubes. The design of the Imperial's output stage allows a fair amount of margin for variation in tube characteristics, so any known brand of 6V6 can be installed, and will work properly and be appropriately self-biased.

Tube Quality

Currently manufactured tubes are built in China, Russia, or the Czech Republic, and are not built to the same quality standards as tubes manufactured by the U.S. manufacturers in the “glory days” of tube manufacturing.

We musicians choose to use vacuum tubes because of their tone, but we need to accept that the tubes available to us these days can be imperfect devices, and are most certainly the least reliable component in the entire amplifier.

It would seem that the obvious solution would be to use new-old-stock tubes that were made back in the “glory days”, when tubes were properly made. However, I’ve lately been finding that much of the available stocks of such “new old stock” tubes are either gassy, noisy, or unreliable – I do believe that we’ve reached the bottom of the barrel of NOS tubes.

Tube problems generally reveal themselves as a crackling noise which can occur continuously, sporadically, in response to mechanical vibration, or in response to your playing (e.g. a crackling or other type of noise which occurs only when you hit a note).

We subject all tubes to a thorough burn-in and test procedure to ensure that they are fully up to spec and operating perfectly. However, you must be aware that the majority of tube failures occur early in their life, and may come about as a result of the jostling and jarring that an amp can receive in shipping. In spite of the exhaustive testing we perform at the shop, early-life tube problems cannot always be found in such testing. The first two months or so are the most tenuous period for any set of tubes. Most manufacturing defects will be revealed in the first two months of their life, but many are not detectable in initial testing, even after a burn-in period.

If you notice any noises, cracking, or any other odd behavior of your amplifier in this period, note that it is most likely to be the result of a defective tube, and should be debugged as such.

TONE KING LIMITED LIFETIME WARRANTY

Thank you for choosing Tone King. Tone King manufactures some of the world's most reliable hand-wired, all-tube amplifiers and speaker cabinets. Tone King takes great pride in an extremely thorough testing procedure which is implemented on each product prior to shipment. In the unlikely event that you have a problem with your amplifier, please refer to warranty below. Tone King stands behind our products like no other and we're here to help you!

AMPLIFIERS: Tone King offers a limited lifetime warranty to the original purchaser that a Tone King amplifier will be free from defects in material and workmanship. A dated sales receipt will establish coverage under this warranty, PLEASE KEEP YOUR PROOF OF PURCHASE TO USE YOUR WARRANTY. This warranty does not cover service or parts to repair damage caused by accident, neglect, abuse, normal & wear, disaster, misuse, abuse, over-powering, negligence, inadequate packing or shipping procedures and service, repair or any modifications to the product which have not been authorized or approved by Tone King in writing. **ANY MODIFICATION TO THE AMPLIFIER WILL VOID YOUR WARRANTY.** If this product is defective in materials or workmanship as warranted above, your sole remedy shall be repair or replacement by Tone King as provided below.

CAUTION: Do NOT attempt to repair, modify or service your amplifier by yourself!!! Please read the instruction manual for all safety notifications, warnings and instructions. Tone King, like all tube amplifiers, have extremely high voltages that can cause serious injury or death. Do not remove the chassis from the amplifier. All repair and service work must be performed by Tone King or an authorized service center of Tone King. ANY UNAUTHORIZED REPAIRS WILL VOID YOUR WARRANTY.

TUBES: Tone King warrants the original purchaser that the specific tubes used in Tone King will be free from defects in material and workmanship for a period of 90 days from the original date of purchase. A dated sales receipt will establish coverage under this warranty. This tube warranty will automatically terminate 90 days after the original retail sales date. This tube warranty is in lieu of all other expressed warranties. If tubes fail within the 90 day warranty period your sole remedy shall be replacement of tubes as provided below.

RETURN PROCEDURES: In the unlikely event that a defect occurs please call us at 818-505-0391. In most cases we can help you diagnose the problem over the phone. If a product must be sent to us, please follow the procedure outlined below.

- Defective products must be shipped, together with proof of purchase, freight pre-paid and insured to the Authorized Tone King Service Center or directly to Tone King.
- If a product must be returned to Tone King for warranty replacement/repair, a

Return Authorization Number must be obtained from our Customer Service Department prior to shipping the product.

- Please contact Tone King Customer Service Department for the Authorized Tone King Service Center nearest you.
- Products must be shipped in their original packaging or its equivalent; in any case, the risk of loss or damage in transit is to be borne by the purchaser.
- The Return Authorization Number must appear in large print directly below the shipping address.
- Always include a brief description of the defect, along with your correct return address and telephone number.
- When calling to inquire about a returned product, always refer to the Return Authorization Number.

If Tone King determines that the unit was defective in materials or workmanship at any time during the warranty period, Tone King has the option of repairing or replacing the product at no additional charge, except as set forth below.

- All replaced parts become a property of Tone King. Products replaced or repaired under this warranty will be returned via ground shipping within the United States or Canada - freight prepaid.
- Tone King is not responsible for costs associated with expedited shipping, either to Tone King or the return of the product to the customer.

All warranty repairs outside the United States and Canada must be directed to the dealer or distributor from which you purchased the product.

INCIDENTAL OR CONSEQUENTIAL DAMAGE: In no event will Tone King be liable for any incidental or consequential damages arising out of the use or inability to use of any Tone King product, even if a Tone King dealer has been advised of the possibility of such damages, or any other claim by any other party. Some states do not allow the exclusion or limitation of consequential damages, so the above limitation and exclusion may not apply to you. This warranty gives you specific legal rights and you may also have other rights which may vary from state to state.

FOR YOUR PROTECTION: Please complete the warranty registration online at www.ToneKingAmplification.com within (10) ten days of the date of purchase so that we may contact you directly in the event a safety notification issued in accordance with the 1972 Consumer Product Safety Act.

CUSTOMER SUPPORT: Our dedicated and friendly staff is ready to help you with any warranty or product questions you may have. Please call us at 323-277-4100 – Monday – Friday 9AM-4PM (Pacific Standard Time)

Thank you again for choosing Tone King and we look forward to a long relationship!

CE Declaration

Premier Builders Guild, LLC
201 S. Highland Avenue, Suite 204
Pittsburgh, PA 15206
412-362-0309



DECLARATION OF CONFORMITY Report #R070212

We, Premier Builders Guild, in coordination with CES Laboratories, declare, taking this declaration under our total responsibility, that the below models are in conformity with the provisions of the following EC Directive(s) when installed in accordance with the installation instructions contained in the product documentation:

2006/95/EEC Low Voltage Directive
2004/108/EEC EMC Directive
2011/65/EEC RoHS-Directive

And that the standards and/or technical specifications have been applied to the following families of products:

	Imperial	Metropolitan
	Galaxy	Falcon
	Sky King	Royalist
	Imperial MK II	Falcon Grande
Manufacturer/Importer	Ironman II Mini	Gremlin

Date: 8/25/2015

Signature: *Christopher W. Fleming*

Name and Title: *Christopher W. Fleming*
U.P. PROJECT ENGINEERING

Approved By:
Chandra Garudachar
President
CES LABORATORIES

Prepared By:
Jyotsna Bedi
23361 Cypress Pt
Mission Viejo, CA 92692